

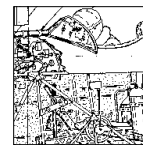

Smithsonian
National Air and Space Museum



NICHOLAS VAN DE GRIFT KARSTENS DRAWINGS

NASM Archives Accession Number 1987-0096

Nicholas Van de Grift Karstens (1913-1987) was an engineer and draftsman who worked for Douglas beginning in 1937. From the mid-1970s he executed a number of detail drawings of aircraft from the early days of aviation. This collection consists of 16 ink-on-polyester detail drawings. **Most drawings are approximately 30"x40" in size.**

HOW TO ORDER ITEMS FROM THIS COLLECTION:

1. Complete the "Ordered By:" and "Ship To:" blocks below. All drawings going to an address in the continental United States will be shipped via UPS, so it is essential to include a street address to which UPS can deliver. If you prefer to have your drawings shipped via U.S. Mail, you must specifically request this service (the shipping cost will be the same).
2. Mark the number of copies you would like of each item in the first column (marked #) of the table on the reverse of this form. Please note that most of these drawings consist of more than one sheet of paper; the full set of sheets for an aircraft type is considered to be **one item**. The price for the item is given in the column marked **Cost**.
3. Add up the total number of ITEMS ordered, and enter the total in the box marked **No. Ordered**. *Because of the large number of orders we receive and the limited staff available to fill these orders, you may request no more than 10 items per order and may have only 1 order in process at a time.*
4. Add up the COSTS of the drawings ordered, and enter the total in the first box of the **Amount** column.
5. Refer to the NASM Archives Shipping Rates form and enter the charge shown in the **Shipping Amount** column.
6. Add up the prices shown in the **Amount** column and enter this total in the box marked **TOTAL**. This is the amount you owe for this order.
7. Complete the PAYMENT METHOD block below and send this packet and your payment to the address below. Please allow four to six weeks for your order to be filled.

ORDERED BY:

Name _____

Organization _____

Address _____

City _____ State _____ Zip/Postal Code _____

Country _____

Telephone _____ Email _____

SHIP TO (if different from "Ordered By"):

Name _____

Organization _____

Address _____

City _____ State _____ Zip/Postal Code _____

Country _____

Telephone _____ Email _____

	No. Ordered	Amount
Total Number of Drawings Ordered (<i>DO NOT EXCEED 10 ITEMS PER ORDER</i>)		
Shipping (see NASM Archives Shipping Rates form):		
TOTAL		



A signed Document Use and Indemnification Agreement is required before reproductions of materials from this collection may be released. Any order not accompanied by a signed agreement cannot be filled. Please complete and sign TWO copies; return one to the NASM Archives and keep the second signed copy for your records. If you need to obtain blank agreement forms, please contact the NASM Archives before submitting this order.

Payment Method

NOTICE: *These items are provided for historical and reference use only. The National Air and Space Museum and its donors assume no liability for any loss or damage resulting from or in any way connected to other use of this information. Not for commercial use or further dissemination.*

CHECK OR MONEY ORDER ENCLOSED
(in US Funds drawn on a US bank, payable to **National Air and Space Museum**)

CREDIT CARD

Type: MasterCard VISA

Account Number _____ Exp. Date _____/_____/____

Card Holder (print): _____

Card Billing Address (print): _____

I authorize the Smithsonian Institution to bill my credit card for the amount shown above under "TOTAL"

Authorized Signature _____ Date _____

Send Order and Payment to:

**Smithsonian Institution
P.O. Box 37012
National Air and Space Museum,
Rm.3100, MRC 322
Washington, DC 20013-7012**

NICHOLAS VAN DE GRIFT KARSTENS DRAWINGS

NASM Archives Accession Number 1987-0096

#	Aircraft Type	Item No.	Sheets	Cost
	Curtiss A-3 Falcon	DD-0061256	1	\$ 9.00
	Douglas DC-1	DD-0061257..8	2	\$ 18.00
	Douglas XO2D-1	DD-0061259..62	4	\$ 36.00
	Fiat CR.32 (20"x31")	DD-0061263	1	\$ 4.00
	Fokker D.VII	DD-0061264..7	4	\$ 36.00
	Great Lakes 2T-1 (25"x36")	DD-0061268	1	\$ 6.00
	Waco UPF-7	DD-0061269..71	3	\$ 27.00

Unless noted all drawings are approximately 30" x 42"

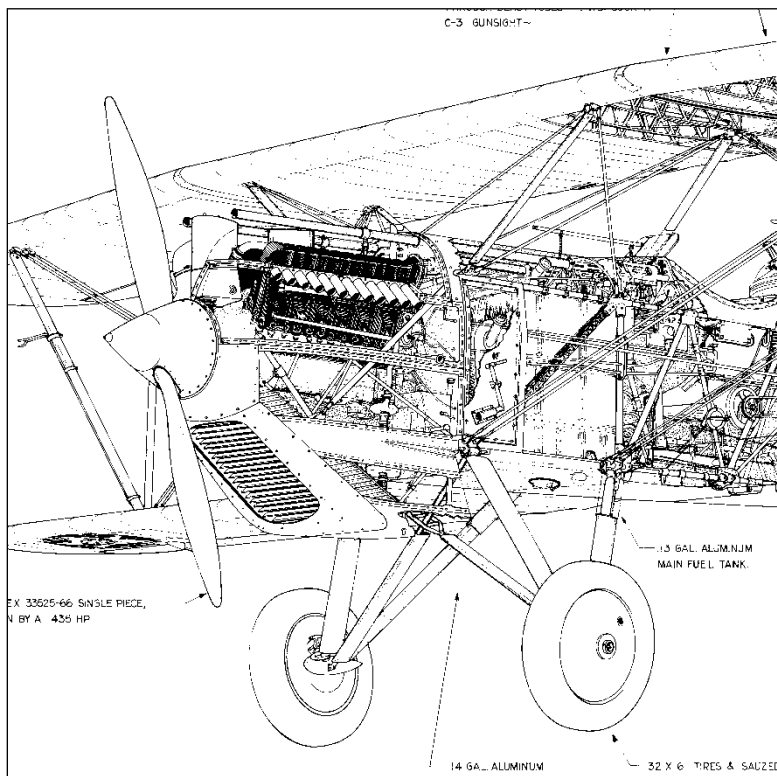

Detail reduced from Nicholas Karstens' drawing of the Curtiss A-3 Falcon.